

UAZ HUNTER

AN OFF-ROAD LEGEND



CHOOSE YOUR OWN WAY



HISTORY

The modern UAZ Hunter is a passionate adventurer. It originates from complete confidence in the car's reliability in any off-road conditions. It was nurtured by generations of owners who were able to travel to unexplored corners of the Earth only thanks to this UAZ model. In 1972 the Ulyanovsk Automobile Plant presented a new off-road vehicle—UAZ-469.

In 1974 serial versions of three UAZ-469 with reinforced suspension conquered the height of 4,000 meters above sea level on unpredictable and

dangerous serpentine slopes of Elbrus. Over decades of active service life UAZ-469 gained a reputation of an industrious worker and uncompromising fighter against hard driving conditions. That is exactly why it became the basis for a new generation of cars—UAZ Hunter.

We have preserved the traditions of the classical off-road vehicle for those who prefer to choose their own path preserved the traditions of the classical off-road vehicle for those who prefer to choose their own path.

FOLLOW TRADITIONS

MORE THAN 40 YEARS OF UAZ DESIGN AND OPERATION EXPERIENCE IN THE HARDEST CONDITIONS LET US SPEAK ABOUT IDEAL OFF-ROAD DESIGN OF UAZ HUNTER'S CHASSIS. THE BASIS OF UAZ HUNTER'S RELIABLE CHASSIS IS A FRAME TYPE STRUCTURE WHICH IS MORE RIGID THAN AN OPEN-ENDED SUPPORTING STRUCTURE AND IS MORE UNIVERSAL THAN UNIBODY CONSTRUCTION. MODERN UAZ HUNTER'S TIME-PROVEN CHASSIS IS STRONG, DURABLE, UNIVERSAL AND ADAPTED TO AN EXTENSIVE RANGE OF OPERATING CONDITIONS



PASSABILITY



STEERING

A highly reliable extended-lifetime mechanism withstands extreme loads when driving off-road

AXLES

Unitized Spicer-type axle assembly on the front and rear shafts ensures reliability of suspension and transmission with a high degree of ruggedness. It is easy to maintain and has an extended lifetime

SUSPENSION

- A front spring suspension guarantees good driveability, passenger comfort and easy maintenance
- An anti-sway bar on the front suspension reduces the body roll of the vehicle, improves driveability and raises the degree of safety and comfort
- A rear suspension with three leaf springs provides resistance to extreme loads and off-road reliability

BRAKE SYSTEM

- A two-piston brake arrangement guarantees a stable high braking force as well as reliability and increased lifetime of the unit
- Front disc brakes improve stopping performance and increase efficiency both on and off-road
- An electronic brake force distribution system distributes the brake force of the wheels on the front and rear axles depending on the vehicle load and prevents them from locking
- Located on a cardan shaft, the parking brake is protected from exposure to snow and dirt and is easy to maintain

KEEP MOVING FORWARD

IMAGINE A MOST INCREDIBLE ROAD SCENARIO:
STEEP SLOPES, UNPREDICTABLE RISES, TREACHEROUS WATER OBSTACLES!

FOUR-WHEEL DRIVE SYSTEM

UAZ Hunter is able to withstand any off-road conditions thanks to a part-time four-wheel drive with an underdrive. With increased off-road capability, your Hunter will not give up even in most complicated situations. And on a paved road you will experience how confidently your new UAZ accelerates and follows its driving trajectory

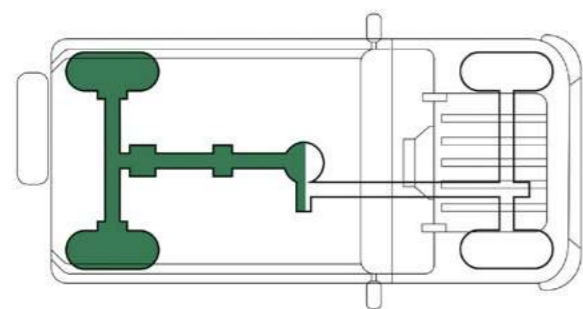

2H Rear-wheel drive
Provides fuel savings as 100% torque is transferred to the rear axle

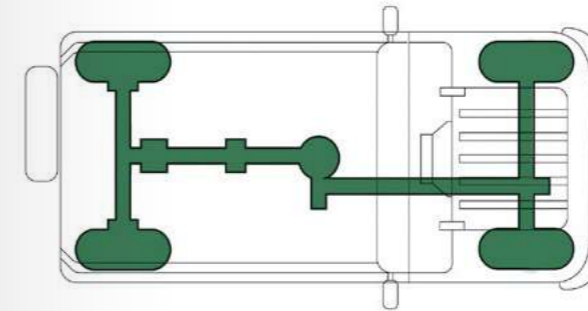

4H Four-wheel drive
The torque is distributed between the front and rear axles 50:50. Used when moving on slippery surfaces or off-road

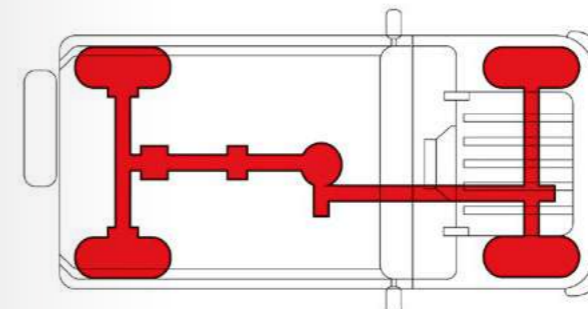

4L Four-wheel drive and low range gears
Provides maximum thrust and is used when driving in extreme off-road conditions

REMAIN TRUE TO MILITARY ORIGIN

New UAZ Hunter still preserves the legendary features of classical off-road vehicles from Ulyanovsk. A military vehicle adapted to civilian life with minimal changes still embodies such values as simplicity, practicality and reliability.

A finely calibrated geometry of the body lines that we recognize at first sight. Composed and confident, this car was created for encountering the most unpredictable circumstances



Exterior



Soft-top available



A durable, time-tested bumper



A full-sized spare wheel



A metallic fine mesh grille protects the radiator from aggressive environment

READY FOR ANY ADVENTURE

EXPEDITION

UAZ Hunter Expedition is especially designed for fans of extreme off-roading, has all the necessary accessories and equipment, has been tested in tough off-road environments and has satisfied all certification requirements.



Exterior



Electric winch

The electric winch has passed all the necessary strength tests and checks for electrical compatibility with the vehicle. It does not interfere with the engine cooling system.



Tailgate

More convenient than a regular car door when it comes to frequent loading and unloading of equipment.



Two-tone colors

The spirit of adventure is reflected in its brightness – Stand out from the others!



Tires BFGoodrich T/A 235/85 R16" With black steel rims

Extra strong AT-tires - tested and proven on hundreds of expedition trips will not let you down, whatever the surface is. Modified arches allow you to install wheels of larger diameters. Road clearance – 241 mm.



Power elements

Front reinforced bumper is equipped with towing loops which allow you to install a winch and use a jack. Rear reinforced bumper with a tow bar, a hole for a jack and mounting for the spare wheel.



Reinforced running boards with two crossbeams

Tested for durability and wholly suitable for lifting the vehicle by means of a jack - even when fully loaded and bogged down.

REACH INNER HARMONY

A HIGH DRIVING POSITION WITH A CONVENIENT ARRANGEMENT OF CONTROLS AND AN ERGONOMIC DESIGN OF THE DRIVING SEAT PROVIDE EXCELLENT VISIBILITY

The high driving position helps to control the situation on the road, improves driveability and raises the level of safety under all circumstances. The front seats have an additional lengthwise adjustment range



Interior

Comfort, simplicity and functionality make the interior of the new UAZ HUNTER fully prepared for any situation.

The distance between the front seats and the backseat allows easy entry into the cabin.

All the materials of the cabin are designed for high loads and possess increased strength.

The fabric of the seats is so practical that it can be washed with regular water.

There is always room for important small items in the deep and wide niches in the front and back doors and the trunk

A handle for easy getting in and out of the front of the cabin



A reliable window opening and locking mechanism



A classical shape of the gear knob



An ergonomic UAZ steering wheel



A classical dashboard combines informativeness, durability and practicality



A spacious backseat row



Comfortable trunk loading angle



For transportation of large-size cargo and equipment the rear seats can be folded down 60/40 or turned into a bed by extending to 180°

IT'S TIME TO USE FORCE!

THE ENTIRE ENGINE POWER WITH A RELIABLE FIVE-SPEED MANUAL GEARBOX IS IN YOUR HANDS

2.7 L 135 hp gasoline engine

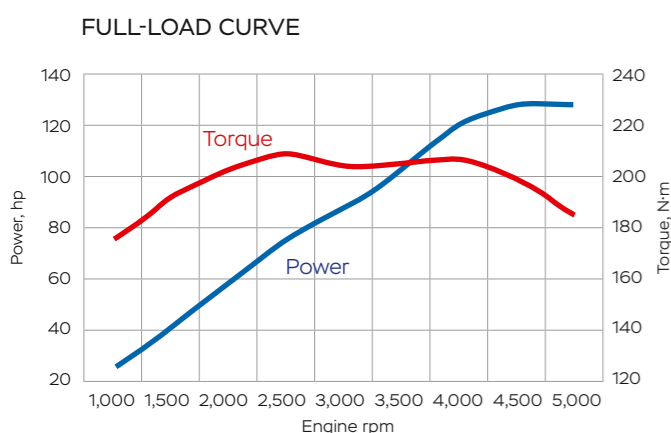

An excellent gasoline engine is famous for its time-tested design, low fuel quality requirements and resistance to off-road driving.



The reliable and powerful engine of the new UAZ Hunter can be used to its full capacity under any circumstances. The 2.7 L gasoline engine with the 210 N·m torque has 135 hp. The engine properties of the new UAZ Hunter allow utilization of 90% torque in the range between 2,000 and 4,500 rpm. This wide range gives the driver unlimited possibilities in any driving situation!

2.2 L 114 hp diesel engine

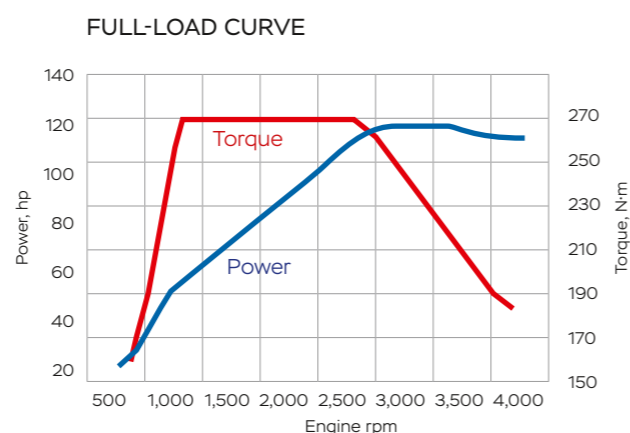

Designed in cooperation with leading engineering companies from abroad the diesel engine powering the new UAZ HUNTER is equipped with Common Rail system of the world – known brand BOSCH and the timing chain allowing you to significantly reduce the vehicle maintenance costs.



TRANSMISSION

A five-speed manual gearbox with an optimally chosen gear ratio makes a trip in the new UAZ Hunter even more pleasant and comfortable on any road! A trip on an asphalt surface will be smoother and more efficient. And five forward gears will give you control over any off-road terrain.

CHOOSE YOUR HUNTER

TECHNICAL CHARACTERISTICS

Geometry and mass		
Number of passengers	5	
Length, mm	4,100	
Width with/without mirrors, mm	2,010 / 1,730	
Height, mm	2,025	
Wheelbase, mm	2,380	
Front/rear track, mm	1,465 / 1,465	
Road clearance, mm	210	
Wading depth, mm	500	
Curb weight, kg	1,845	
Gross weight, kg	2,520	
Load-carrying capacity, kg	675	
Engine and transmission		
Type of engine	gasoline engine EURO-5	diesel engine EURO-4
Fuel	gasoline with an octane number not less than 92	diesel fuel
Cubic capacity, L	2.693	2.235
Maximum power, hp (kW)	135 (94.1) at 4,600 rpm	113.5 (83.5) at 3500 rpm
Maximum torque, N*m	210 at 2500 rpm	270 at 1800–2800 rpm
Wheel arrangement	4x4	
Gearbox	five-speed, manual	
Transfer case	two-speed with a disconnectable front drive axle	
Drive	a full-time four-wheel drive with the ability to automatically disconnect front wheels	
Suspension, brakes and tires		
Front brake	disc	
Rear brake	drum	
Front suspension	dependent, spring with an anti-sway bar	
Rear suspension	dependent, on two longitudinal semi-elliptical springs with a small number of leaves	
Tires	225/75 R16	
Speed and efficiency		
Maximum speed, km/h	130	120
Fuel consumption, L/100 km (at 90 km/h)	13.2	10.6
Total fuel tank capacity, L	72	

UAZ HUNTER CLASSIC VERSIONS AND ITS BODY COLORS



Classic (hard top)



Classic (soft top)



Classic (Trophy package)

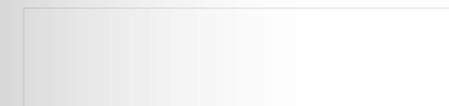

Non-metallic White

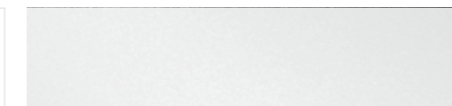

Silver metallic



Dark grey metallic



Black metallic



Brown metallic



Dark green metallic

UAZ HUNTER EXPEDITION COLORS



Non-metallic Orange



Green (Khaki)



Brown gray metallic

WHEEL RIMS

16-inch rims provide unsurpassed comfort even in off-road conditions



16-inch steel rims



16-inch steel rims

16-inch
"Trophy" alloy rims
(available for Trophy package only)

FIND YOUR DISTRIBUTOR OR BECOME A NEW ONE

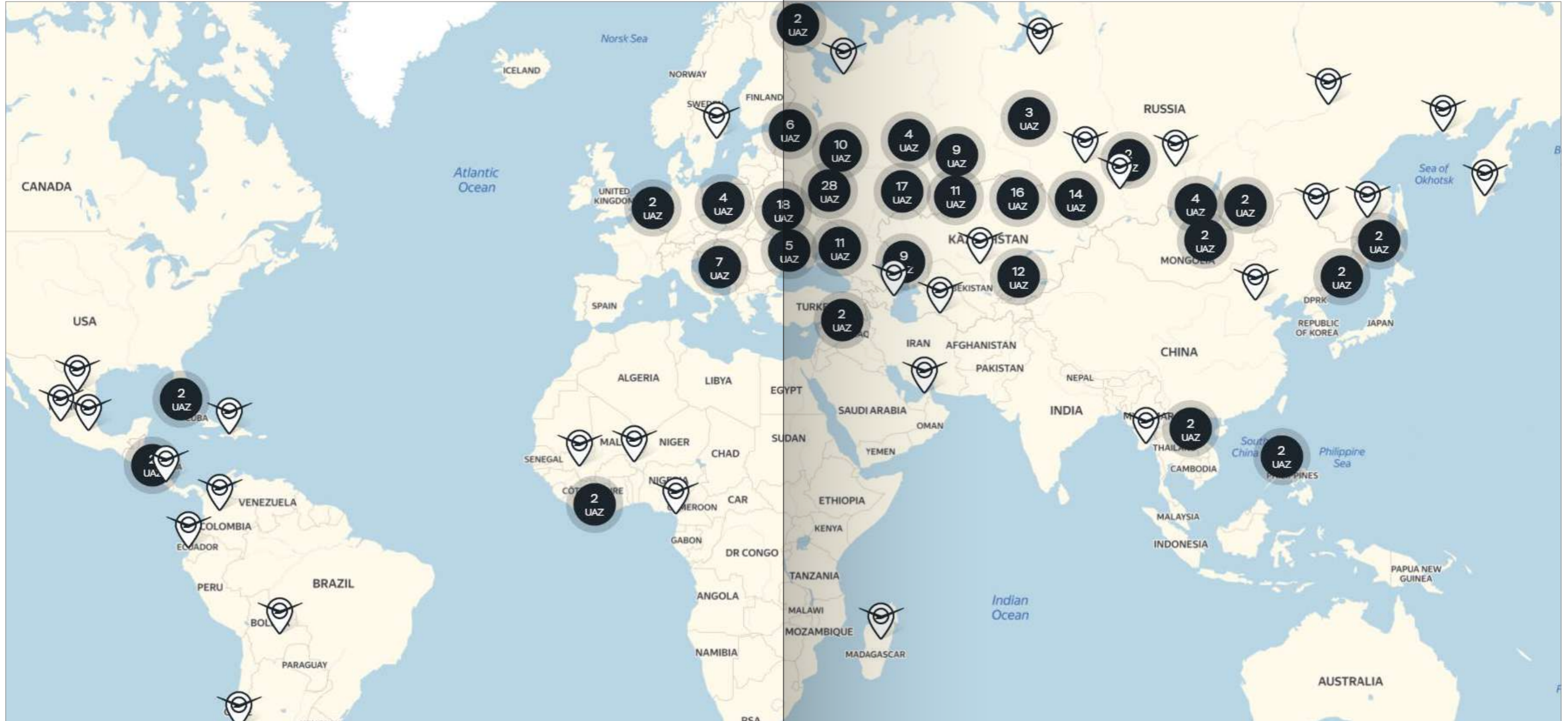

- Africa
- America
- Asia
- CIS countries
- Europe
- Middle East and North Africa



A real SUV should adequately cope with any tests. Modern technological solutions and the latest equipment from the world's leading manufacturers guarantee you absolute passage, with the highest level of comfort and safety of our cars. For more than 75 years, our SUVs have been repeatedly confirmed their outstanding product quality in extreme climates and challenging road conditions..

Hundreds of thousands of kilometres in the steppes of Central Asia, the mountains of Transcaucasia, across the deserts of Africa and the expanses of the Far North, and finally, the victorious ascent to the highest mountain in Europe – Elbrus, all this have allowed our cars to become a symbol of overcoming any obstacles in the harshest of conditions. UAZ. A symbol of passage. A mark of excellence.

WWW.UAZ.GLOBAL

For buying and maintenance of UAZ vehicles consult the official dealers in your region.

The contents of this booklet are meant only for advertising purposes. The colors of the body and finishing of the cabin shown in this booklet can differ slightly from the real colors because of printing color limitations. The pictures may show accessories and elements of an extended configuration that are not included in the basic configuration. Some equipment can differ depending on the sales market. The company reserves the right to change the technical characteristics and configurations mentioned in this booklet without prior notice.